

# Procedure of changing the **Luftmy** Sensor

**model: PUV310C(8126AS)**



# Luftmy Sensor

# Tools

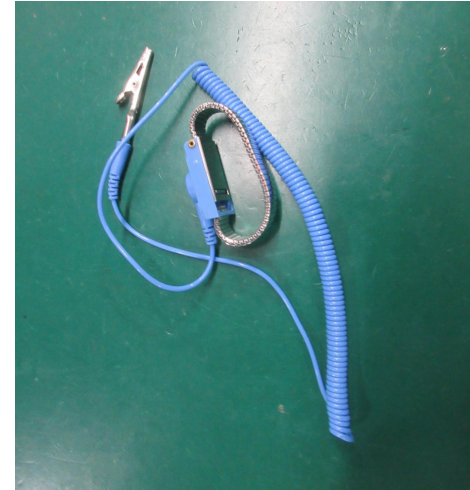

electrostatic bracelet  
(Better to ware)

图1

peel of the panel



图2

残胶处理干净

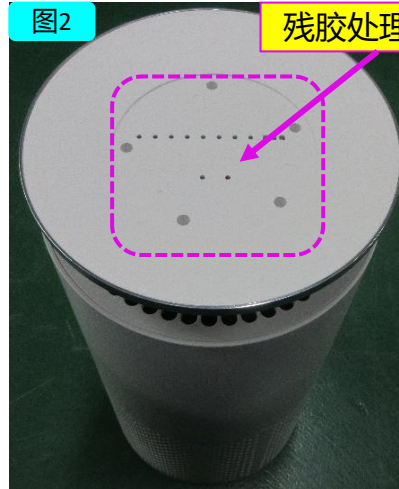

Can use a flat screw driver to help peel of the panel



图1

Unscrew above five screws

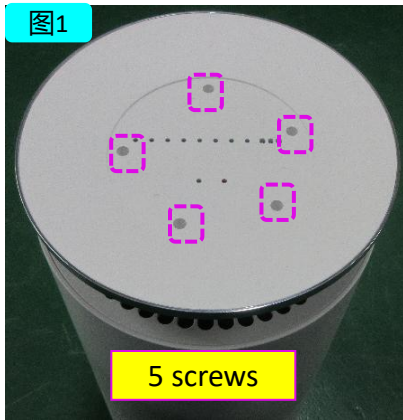

图2

unplug above five connectors

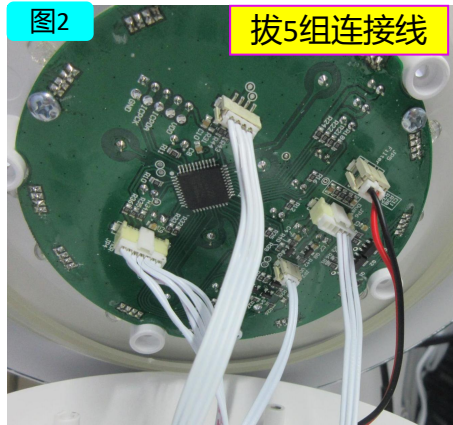

图3

Unscrew above 4 screws



图4

Take off above holder



图5

Unscrew above 3 screws from airlet



图6

Take off the outlet.

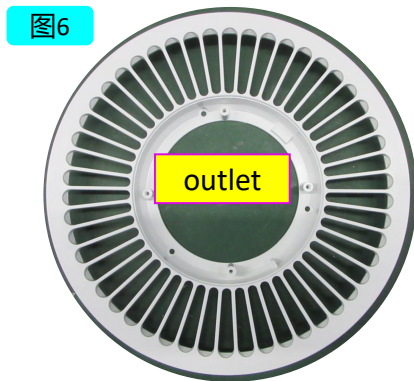

图7

Unscrew above 4 screws.

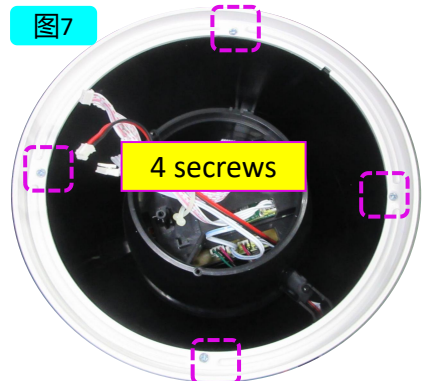

图8

Take off the top housing.



Remove the 3M tape.

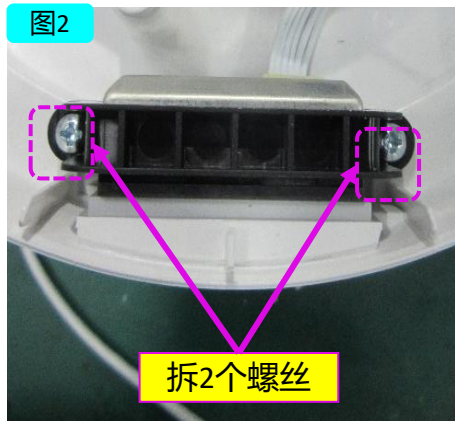

Unscrew the 2 screws from the sensor holder



Take off the sensor holder

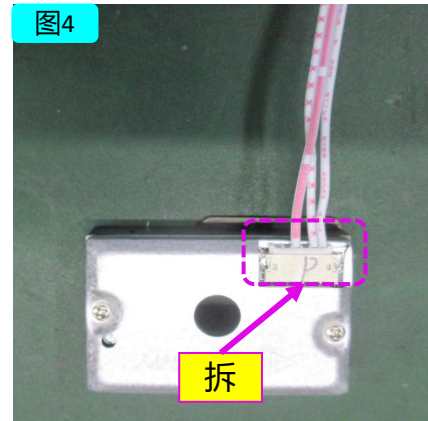

Unplug the sensor connector

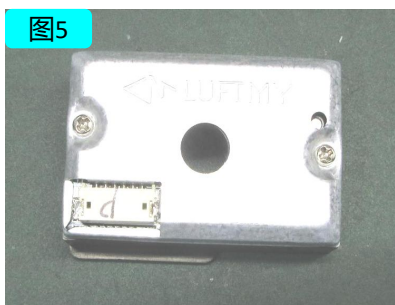

旧粉尘传感器

Take away the sensor.



图1

新粉尘传感器

Get a new Luftmy sensor

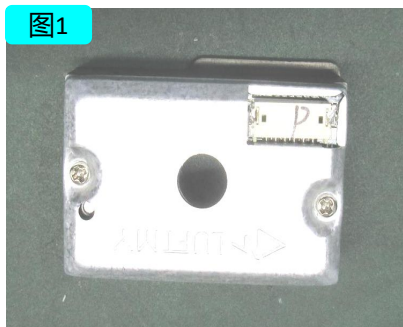

图2

插连接线

Plug in the connector.

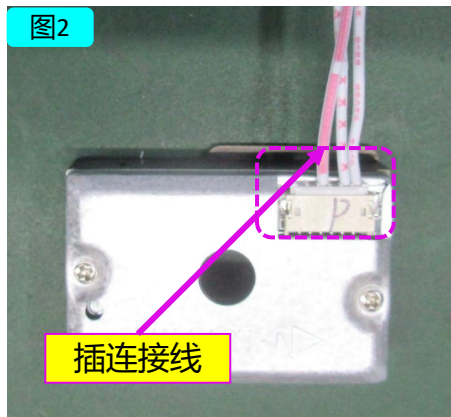

图3

整形

避开中心孔

Make sure the cord won't cover the sensor hole

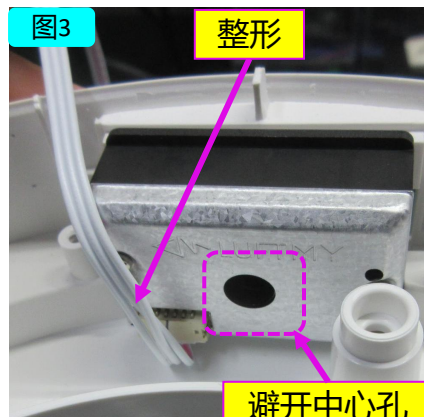

图4

固定

Fix the sensor into the port

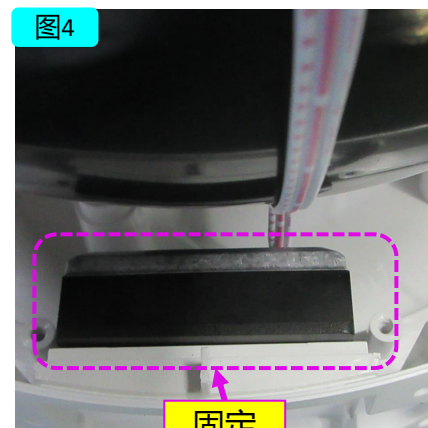

图5

贴紧

Make sure it fix tight.

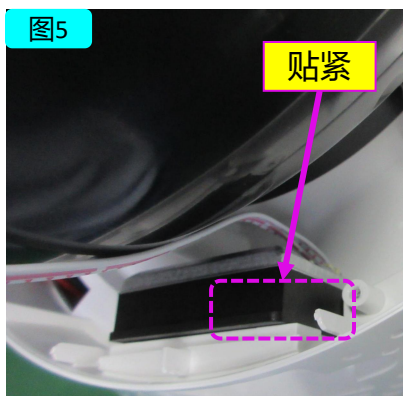

图6

装粉尘固定架

Fix the sensor holder with 2 screws.

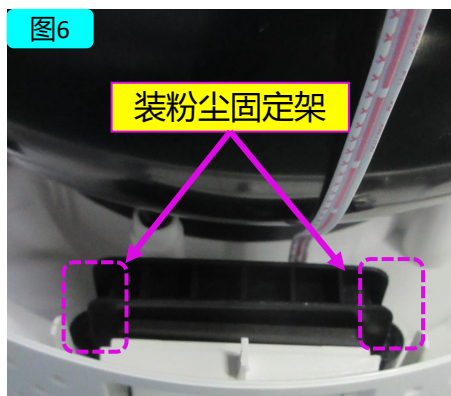

图7

锁

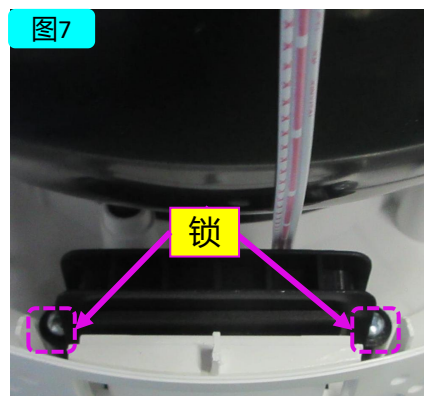

图8

贴3M胶带

连接线向上拉直

Pull stright the sensor cord and stick back the 3M tape.

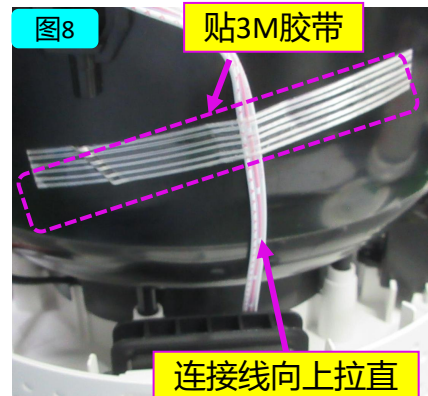
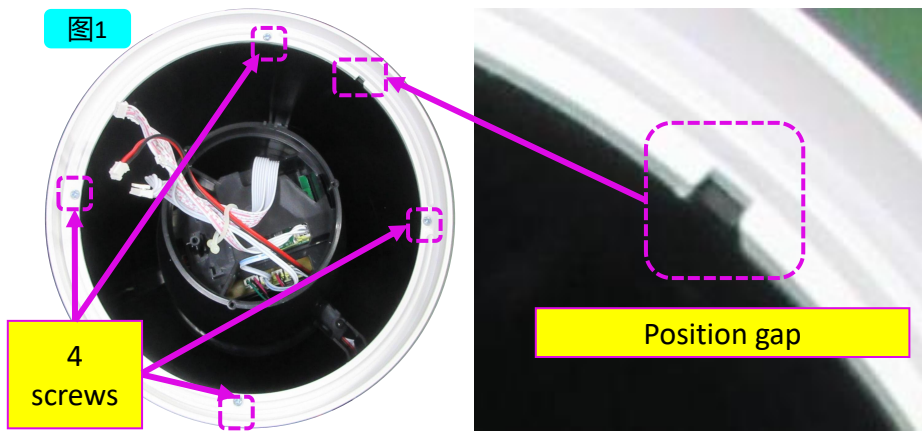

Fix the top housing back to the unit. Pay attention to the gap for right direction.

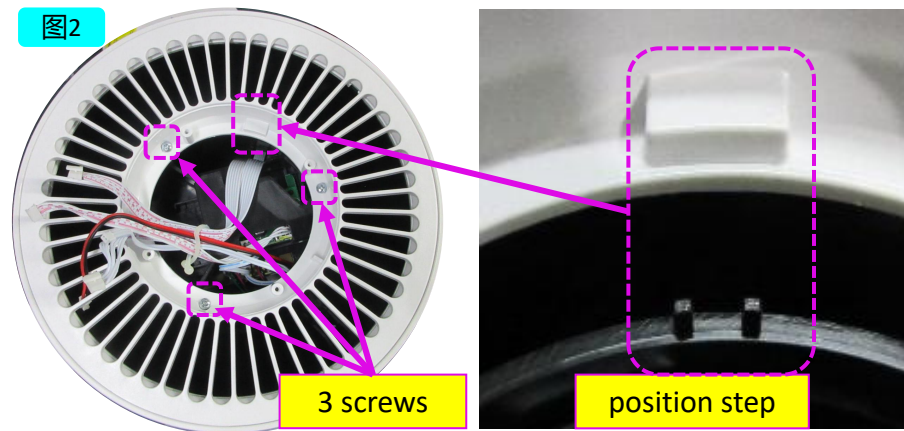

Fix the outlet back to the unit, pay attention to the step for right direction.

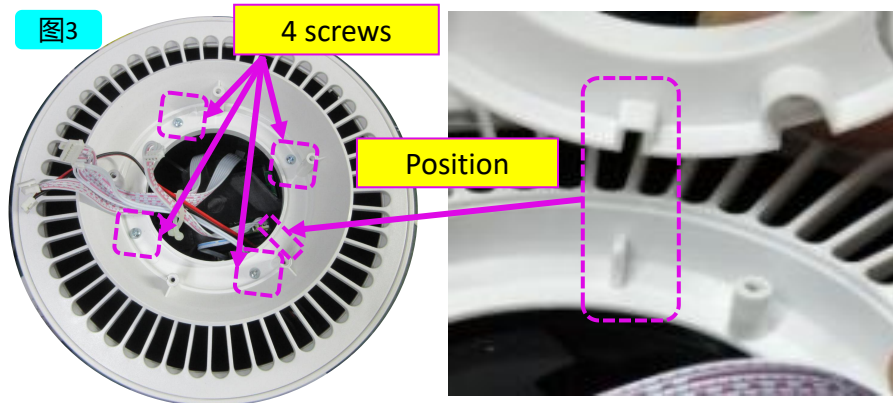

Fix the holder back to the unit, pay attention to the step for right direction.

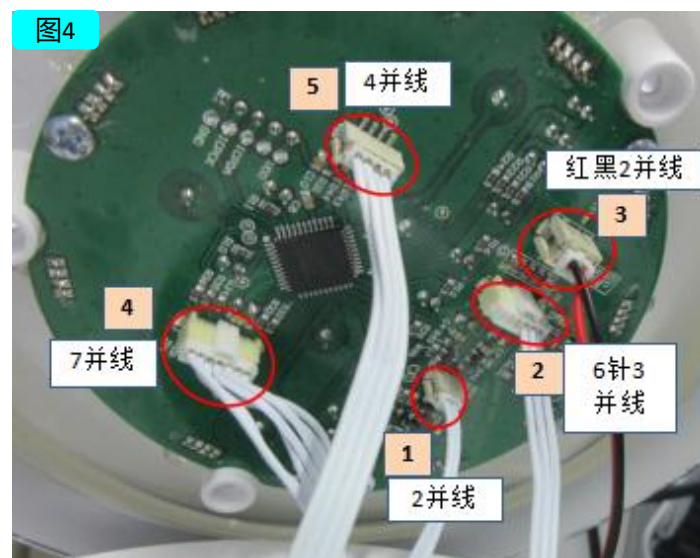

Plug in above five connectors.



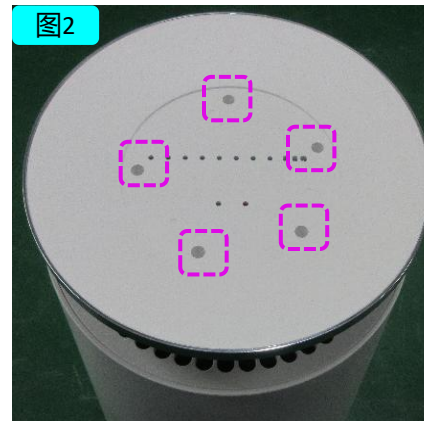
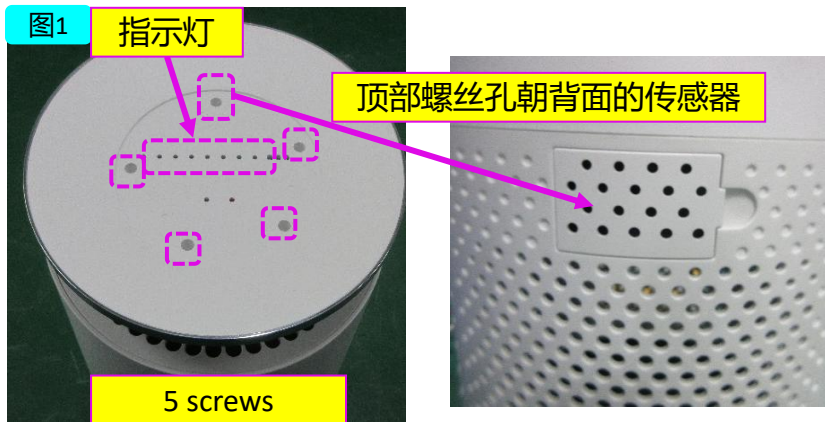

Fix the top part back the unit. Make sure the direction is right.

Stick tight the touch panel.

